

Inclusive trampoline

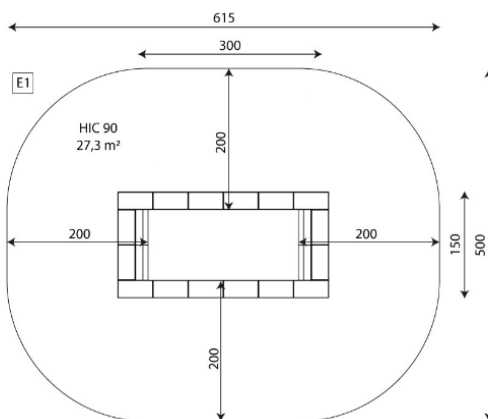
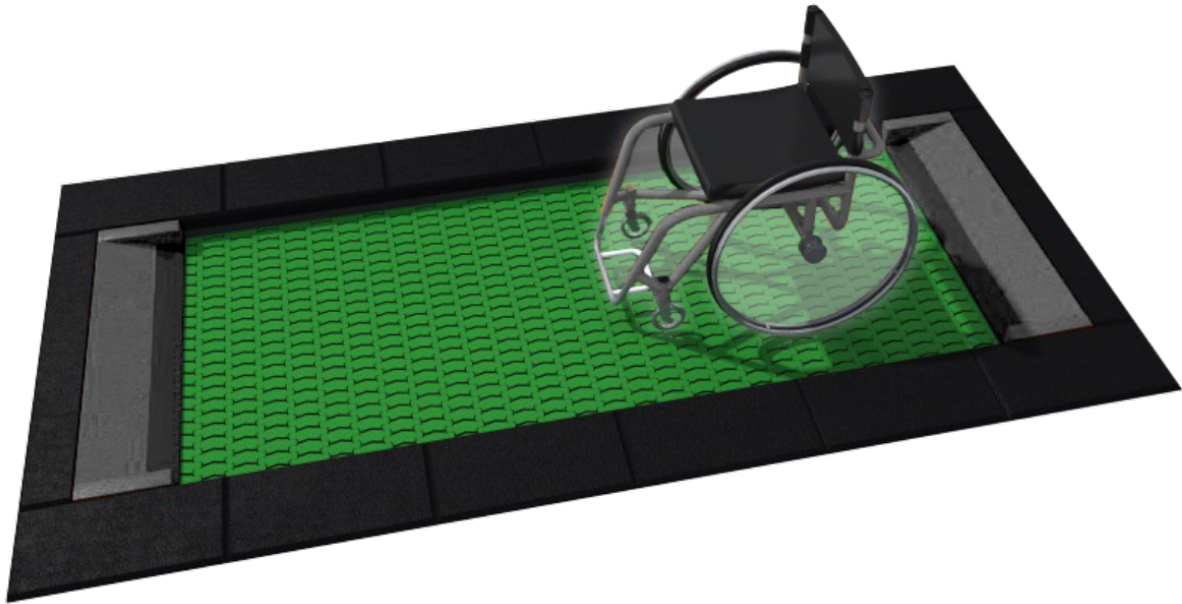

RECTANGULAR

JTRAR

3+



Inclusive rectangular trampoline.
Maximum user weight: 130 kg

Ref.	A x B			
JTRAR01	A=1500mm B=2000mm	15m ²	0.9m	1
JTRAR02	A=1500mm B=2500mm	25.32m ²	0.9m	1
JTRAR03	A=1500mm B=3000mm	27.81m ²	0.9m	1
JTRAR04	A=1500mm B=5000mm	37.81m ²	0.9m	1

Materials:

Structure : Formed by a galvanized metal frame, EPDM rubber protective collar.

Jumping net : Produced by plastic pieces with a non-slip surface intertwined with each other and steel Springs swings attaching to the frame.

- None of the materials require special treatment for disposal.
- If the equipment is subject to severe use, the maintenance plan should be increased.
- Do not use the product before completing the installation/maintenance.
- Consult maintenance instructions.

Largest piece (mm): / Heaviest piece (kg):

IMPACT ZONE: Required safety surface. Floor covering according to EN1176-1:2017 is recommended.

Spare parts availability: 10 years.



RAL 9005

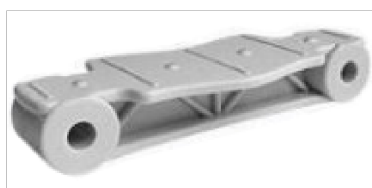

RAL 7035



RAL 1018



RAL 6029



RAL 3020

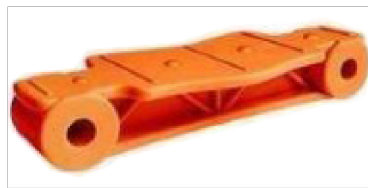

RAL 2005



RAL 5005

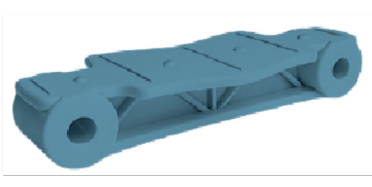

RAL 5024

Ground anchoring screws not included.

Playful features:

